

Rubber Expansion Joints & Accessories



Rubber Expansion Joints - Flange x Flange

PART NUMBER STRUCTURE

| Part Number Section | Options |
|---------------------|--|
| Type | AMS = Single Sphere (Steel) SAMS = Single Sphere (Stainless Steel) AMT = Twin Sphere (Steel) SAMT = Twin Sphere (Stainless Steel) |
| Size | XXXX = Size in inches going out 2 decimal places |
| Body Material | NE = Neoprene EP = EPDM BN = Buna-N/Nitrile/NBR |
| Flange Material | STL = Zinc Plated Steel 304L = 304L Stainless Steel 316L = 316L Stainless Steel |
| Class | 150 = 150# Drilling 300 = 300# Drilling PXX = DIN PN16 Drilling (available upon request) |
| <i>Example</i> | AMSO200-NE-STL-150 = Single Sphere Expansion Joint with Neoprene Body and Steel Flanges with 150# Drill Pattern |

OPERATING CONDITIONS

| Size Range | 1" - 12" | 14" - 24" |
|-----------------------|---|---|
| Operating Pressure | up to 214 psi | up to 114 psi |
| Operating Temp Range* | 14° - 170 °F (Neoprene) 14° - 210 °F (EPDM) 14° - 170 °F (Buna-N/ Nitrile/NBR) | 14° - 170 °F (Neoprene) 14° - 210 °F (EPDM) 14° - 170 °F (Buna-N/ Nitrile/NBR) |
| Burst Pressure | 853 psi | 340 psi |
| Vacuum Rating* | Contact API Sales | Contact API Sales |

MATERIALS

| Part | Part Description | Material |
|------|------------------|---|
| 1 | Flanges | Mild Steel - Zinc Plated steel or Stainless Steel |
| 2 | Reinforcing Wire | Mild Steel |
| 3 | Tube | Synthetic Rubber |
| 4 | Cover | Synthetic Rubber |
| 5 | Reinforcing Cord | Synthetic Fiber |

****** - Warnings:

- a. Pressure ratings listed in the above table are for up to 110 °F (for Neoprene), and 125 °F (for EPDM). For elevated temperature service, please contact API Sales for actual working pressure ratings.
- b. Limit rods are required in systems that are unanchored and recommended in all other applications.
- c. Not for use in steam applications

Single Sphere Rubber Expansion Joints - Flange x Flange

FEATURES

- Applicable for suction and delivery (discharge).
- Provides sound and vibration isolation.
- Gaskets and packing are not required.
- Floating flanges allow for easy installation.
- Prevents piping system and equipment breakdown by absorbing elongation and contraction caused by temperature variances.
- Absorbs water pulsation and minimizes water hammering.

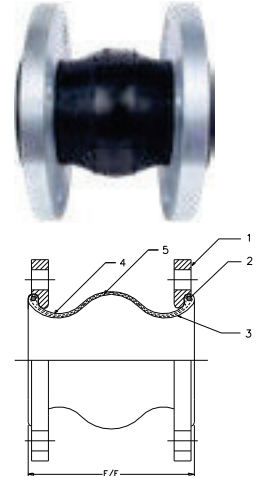

APPLICATIONS

- Pumps & air compressors in air conditioning system & sanitary equipment.
- Refrigeration systems and blowers in industrial plant equipment.
- Feed-water and drainage equipment in marine piping systems.
- Applicable for use in power generation and chemical plants.

DIMENSION & ALLOWABLE MOVEMENTS

ALL DIMENSIONS ARE IN INCHES UNLESS OTHERWISE STATED.

| API Part Number | Size in | Face to Face Dimensions in | Ø B.H.C. | | Allowable Motion Ratings* | | | | Installation Tolerances | | | |
|-----------------|------------|----------------------------------|-------------|-------------|---------------------------|------------|---------|---------|-------------------------|------------|---------|---------|
| | | | PN 10 in | PN 16 in | Compression | Elongation | Lateral | Angular | Compression | Elongation | Lateral | Angular |
| (S)AMS0100 | 1 | 6 | 3.1 | | 0.50 | 0.38 | 0.50 | 15° | 0.19 | 0.13 | 0.25 | 5° |
| (S)AMS0150 | 1.5 | 6 | 4.3 | | 0.50 | 0.38 | 0.50 | 15° | 0.19 | 0.13 | 0.25 | 5° |
| (S)AMS0200 | 2 | 6 | 4.9 | | 0.50 | 0.38 | 0.50 | 15° | 0.19 | 0.13 | 0.25 | 5° |
| (S)AMS0250 | 2.5 | 6 | 5.7 | | 0.50 | 0.38 | 0.50 | 15° | 0.19 | 0.13 | 0.25 | 5° |
| (S)AMS0300 | 3 | 6 | 6.3 | | 0.50 | 0.38 | 0.50 | 15° | 0.19 | 0.13 | 0.25 | 5° |
| (S)AMS0400 | 4 | 6 | 7.1 | | 0.63 | 0.38 | 0.50 | 15° | 0.19 | 0.13 | 0.25 | 5° |
| (S)AMS0500 | 5 | 6 | 8.3 | | 0.63 | 0.38 | 0.50 | 15° | 0.19 | 0.13 | 0.25 | 5° |
| (S)AMS0600 | 6 | 6 | 9.5 | | 0.63 | 0.38 | 0.50 | 15° | 0.19 | 0.13 | 0.25 | 5° |
| (S)AMS0800 | 8 | 6 | 11.6 | 12.0 | 0.63 | 0.38 | 0.50 | 15° | 0.19 | 0.13 | 0.25 | 5° |
| (S)AMS1000 | 10 | 8 | 13.8 | 14.0 | 0.63 | 0.50 | 0.75 | 15° | 0.19 | 0.13 | 0.25 | 5° |
| (S)AMS1200 | 12 | 8 | 15.8 | 16.0 | 0.75 | 0.50 | 0.75 | 15° | 0.19 | 0.13 | 0.25 | 5° |
| (S)AMS1400 | 14 | 8 | 18.1 | 19.0 | 0.75 | 0.50 | 0.75 | 15° | 0.19 | 0.13 | 0.25 | 5° |
| (S)AMS1600 | 16 | 8 | 20.3 | 21.0 | 0.75 | 0.50 | 0.75 | 15° | 0.19 | 0.13 | 0.25 | 5° |
| (S)AMS1800 | 18 | 8 | 22.2 | 23.0 | 0.75 | 0.50 | 0.75 | 15° | 0.19 | 0.13 | 0.25 | 5° |
| (S)AMS2000 | 20 | 8 | 24.4 | 26.0 | 0.75 | 0.50 | 0.75 | 15° | 0.19 | 0.13 | 0.25 | 5° |
| (S)AMS2400 | 24 | 10 | 28.5 | 30.0 | 0.75 | 0.50 | 0.75 | 15° | 0.19 | 0.13 | 0.25 | 5° |

Warning: Do not elongate rubber expansion joints when installing for suction service.

“*” - Non Concurrent Ratings.

Twin Sphere Rubber Expansion Joints - Flange x Flange

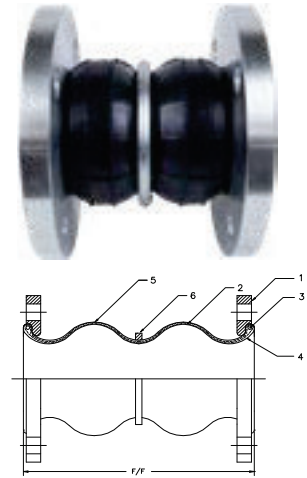

FEATURES

- Applicable for suction and delivery (discharge).
- Designed for greater compression, elongation, and angular movement than the single sphere expansion joint.
- Excellent for absorbing thermal expansion and eliminating sound and vibration.
- Gaskets and packing not required.
- Good electrical insulator.
- Absorbs water pulsation and minimizes water hammering.

APPLICATIONS

- Pressure piping systems in building equipment and general industrial plants.
- Pump and turbine lines used for power generation plants, industrial machinery and universal pump blowers.
- Feed-water & drainage lines for waterworks & sanitary piping systems.
- Pipelines for industrial plants and shipbuilding yards.

DIMENSION & ALLOWABLE MOVEMENTS

ALL DIMENSIONS ARE IN INCHES UNLESS OTHERWISE STATED.

| API Part Number | Size | Face to Face Dimension | Allowable Motion Ratings* | | | | Installation Tolerances | | | |
|-----------------|------|------------------------|---------------------------|------------|---------|---------|-------------------------|------------|---------|---------|
| | | | Compression | Elongation | Lateral | Angular | Compression | Elongation | Lateral | Angular |
| (S)AMT0100 | 1 | 7.00 | 1.50 | 0.75 | 1.25 | 35° | 0.25 | 0.13 | 0.31 | 10° |
| (S)AMT0150 | 1.5 | 7.00 | 2.00 | 1.13 | 1.75 | 35° | 0.25 | 0.13 | 0.31 | 10° |
| (S)AMT0200 | 2 | 7.00 | 2.00 | 1.13 | 1.75 | 35° | 0.25 | 0.13 | 0.31 | 10° |
| (S)AMT0250 | 2.5 | 7.00 | 2.00 | 1.13 | 1.75 | 35° | 0.25 | 0.13 | 0.31 | 10° |
| (S)AMT0300 | 3 | 7.00 | 2.00 | 1.38 | 1.75 | 35° | 0.25 | 0.13 | 0.31 | 10° |
| (S)AMT0400 | 4 | 9.00 | 2.00 | 1.38 | 1.56 | 35° | 0.25 | 0.13 | 0.31 | 10° |
| (S)AMT0500 | 5 | 9.00 | 2.00 | 1.38 | 1.56 | 30° | 0.25 | 0.13 | 0.38 | 10° |
| (S)AMT0600 | 6 | 9.00 | 2.00 | 1.38 | 1.56 | 30° | 0.25 | 0.13 | 0.38 | 10° |
| (S)AMT0800 | 8 | 13.00 | 2.38 | 1.38 | 1.38 | 30° | 0.25 | 0.13 | 0.50 | 10° |
| (S)AMT1000 | 10 | 13.00 | 2.38 | 1.38 | 1.38 | 30° | 0.25 | 0.13 | 0.50 | 10° |
| (S)AMT1200 | 12 | 13.00 | 2.38 | 1.38 | 1.38 | 20° | 0.25 | 0.13 | 0.50 | 10° |
| (S)AMT1400 | 14 | 13.75 | 1.56 | 1.13 | 1.13 | 20° | 0.25 | 0.13 | 0.31 | 10° |
| (S)AMT1600 | 16 | 13.75 | 1.56 | 1.13 | 1.13 | 20° | 0.25 | 0.13 | 0.31 | 10° |
| (S)AMT1800 | 18 | 13.75 | 1.56 | 1.13 | 1.13 | 20° | 0.25 | 0.13 | 0.31 | 10° |
| (S)AMT2000 | 20 | 13.75 | 1.56 | 1.13 | 1.13 | 20° | 0.25 | 0.13 | 0.31 | 10° |
| (S)AMT2400 | 24 | 13.75 | 1.56 | 1.13 | 1.13 | 20° | 0.25 | 0.13 | 0.31 | 10° |

Warning: Do not elongate rubber expansion joints when installing for suction service.

** - Non Concurrent Ratings.

Twin Sphere Rubber Expansion Joints - Union x Union

FEATURES

- Efficient noise and vibration isolation.
- Ability to absorb large displacement due to eccentric, axial, and angular movement.
- Applicable for both suction and discharge.
- Female Threaded Unions allow for easy installation.



APPLICATIONS

- Vibration isolation for small pumps and circular pumps.
- Sewage disposal purifier line.
- Vibration isolation for air-conditioners and pipes.

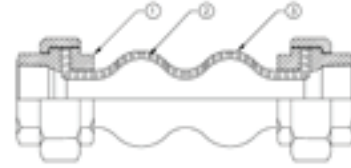

DIMENSION & ALLOWABLE MOVEMENTS

ALL DIMENSIONS ARE IN INCHES UNLESS OTHERWISE STATED.

| API Part Number | Size | Face to Face dimension (L) | Allowable Motion Ratings | | | | Approximate Weight (lbs) |
|-----------------|------|----------------------------|--------------------------|------------|---------|---------|--------------------------|
| | | | Compression | Elongation | Lateral | Angular | |
| AMU0050-XX | 0.5 | 8.00 | 0.88 | 0.25 | 0.88 | 45° | 1.5 |
| AMU0075-XX | 0.75 | 8.00 | 0.88 | 0.25 | 0.88 | 45° | 1.8 |
| AMU0100-XX | 1 | 8.00 | 0.88 | 0.25 | 0.88 | 45° | 2.8 |
| AMU0125-XX | 1.25 | 8.00 | 0.88 | 0.25 | 0.88 | 45° | 3.5 |
| AMU0150-XX | 1.5 | 8.00 | 0.88 | 0.25 | 0.88 | 45° | 4.0 |
| AMU0200-XX | 2 | 8.00 | 0.88 | 0.25 | 0.88 | 45° | 5.0 |

Warning: Do not elongate rubber expansion joints when installing for suction service.

*** - Non Concurrent Ratings.

PART NUMBER STRUCTURE

| Part Number Section | Options |
|-------------------------------------|--|
| Type | AMU = Twin Sphere Union Expansion Joint |
| Size | XXXX = Size in inches going out 2 decimal places |
| Body Material *Denoted with "XX" | EP = EPDM NE = Neoprene |

OPERATING CONDITIONS

| | |
|------------------------|---------------|
| Operating Pressure | up to 150 psi |
| Normal Operating Temp. | 14°- 158° F |
| Vacuum Rating | 25" Hg |
| Burst Pressure | 750 psi |

MATERIALS

| Part | Part Description | Material |
|------|-------------------|----------------|
| 1 | Threaded Union | Malleable Iron |
| 2 | Reinforcing Cloth | Nylon Fabric |
| 3 | Elastomer | EPDM |

*** - Warning:

Pressure ratings listed in the above table are for up to 110 °F (for Neoprene), and 125 °F (for EPDM). For elevated temperature service, please contact API Sales for actual working pressure ratings.

Control Units - Steel (Zinc Plated)**

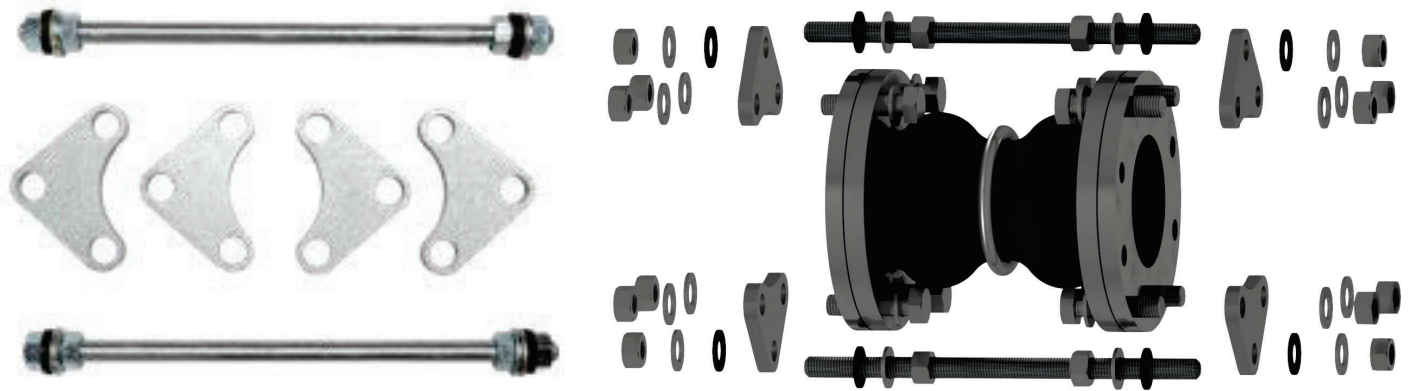

ALL DIMENSIONS ARE IN INCHES UNLESS OTHERWISE STATED.

| Complete unit* API Part Number | Size | Expansion Joint Application | Gusset Plate Part Number | Plate THK. | Plate Weight (lbs) | Control ROD Part Number*** | Approximate Weight (lbs) |
|-----------------------------------|------|--------------------------------|-----------------------------|------------|-----------------------|-------------------------------|-----------------------------|
| CRU0150 | 1.5 | SINGLE/TWIN | CRP0150 | 0.50 | 0.8 | CR0625-14S | 6.4 |
| CRU0200 | 2 | SINGLE/TWIN | CRP0200 | 0.50 | 1.0 | CR0625-14S | 7.2 |
| CRU0250 | 2.5 | SINGLE/TWIN | CRP0250 | 0.50 | 1.3 | CR0625-14S | 8.4 |
| CRU0300 | 3 | SINGLE/TWIN | CRP0300 | 0.50 | 1.6 | CR0625-14S | 9.6 |
| CRUS0400 | 4 | SINGLE | CRP0400 | 0.50 | 1.4 | CR0625-14S | 8.8 |
| CRUT0400 | 4 | TWIN | CRP0400 | 0.50 | 1.4 | CR0625-17T | 9.2 |
| CRUS0500 | 5 | SINGLE | CRP0500 | 0.50 | 1.5 | CR0625-14S | 9.2 |
| CRUT0500 | 5 | TWIN | CRP0500 | 0.50 | 1.5 | CR0625-17T | 9.6 |
| CRUS0600 | 6 | SINGLE | CRP0600 | 0.50 | 1.7 | CR0625-14S | 10.0 |
| CRUT0600 | 6 | TWIN | CRP0600 | 0.50 | 1.7 | CR0625-17T | 10.4 |
| CRUS0800 | 8 | SINGLE | CRP0800 | 0.50 | 2.1 | CR0875-18S | 16.4 |
| CRUT0800 | 8 | TWIN | CRP0800 | 0.50 | 2.1 | CR0875-23T | 17.6 |
| CRUS1000 | 10 | SINGLE | CRP1000 | 0.75 | 3.5 | CR0875-18S | 22.0 |
| CRUT1000 | 10 | TWIN | CRP1000 | 0.75 | 3.5 | CR0875-23T | 23.2 |
| CRUS1200 | 12 | SINGLE | CRP1200 | 0.75 | 5.0 | CR1125-18S | 34.0 |
| CRUT1200 | 12 | TWIN | CRP1200 | 0.75 | 5.0 | CR1125-23T | 36.0 |
| CRUS1400 | 14 | SINGLE | CRP1416 | 0.75 | 5.0 | CR1125-18S | 34.0 |
| CRUT1400 | 14 | TWIN | CRP1416 | 0.75 | 5.0 | CR1125-23T | 36.0 |
| CRUS1600 | 16 | SINGLE | CRP1416 | 0.75 | 5.0 | CR1125-18S | 34.0 |
| CRUT1600 | 16 | TWIN | CRP1416 | 0.75 | 5.0 | CR1125-23T | 36.0 |
| CRUS1800 | 18 | SINGLE | CRP1820 | 0.75 | 6.0 | CR1125-18S | 38.0 |
| CRUT1800 | 18 | TWIN | CRP1820 | 0.75 | 6.0 | CR1125-23T | 40.0 |
| CRUS2000 | 20 | SINGLE | CRP1820 | 0.75 | 6.0 | CR1125-18S | 38.0 |
| CRUT2000 | 20 | TWIN | CRP1820 | 0.75 | 6.0 | CR1125-23T | 40.0 |
| CRUS2400 | 24 | SINGLE | CRP2400 | 1.00 | 7.5 | CR1250-18S | 47.0 |
| CRUT2400 | 24 | TWIN | CRP2400 | 1.00 | 7.5 | CR1250-23T | 49.0 |

Warning: Do not elongate rubber expansion joints when installing for suction service.

** - Complete units consist of the following: 2 Rods; 4 Plates; 8 Nuts; 8 Steel Washers; & 8 Neoprene Washers.

If needed, 3 or more rod sets are available upon request.

*** - Sets are also available in 304/316 Stainless Steel.

**** - Single (S); Twin (T).

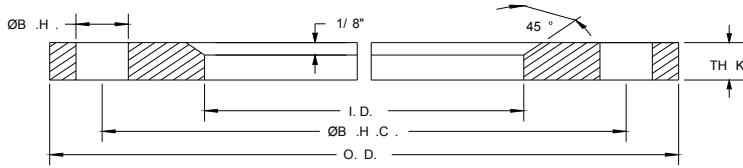

Split Retaining Rings - Class 150 Drill Pattern

| API Part Number | Size | O.D. | I.D. | Ø B.H.C. | Ø B.H. | # B.H | THK |
|-----------------|------|-------|-------|----------|--------|-------|-------|
| (S)RR0050 | 0.5 | 3.50 | 1.50 | 2.38 | 0.630 | 4 | 0.375 |
| (S)RR0075 | 0.75 | 3.88 | 1.88 | 2.75 | 0.630 | 4 | 0.375 |
| (S)RR0100 | 1 | 4.25 | 2.38 | 3.13 | 0.630 | 4 | 0.375 |
| (S)RR0125 | 1.25 | 4.63 | 2.63 | 3.50 | 0.630 | 4 | 0.375 |
| (S)RR0150 | 1.5 | 5.00 | 2.88 | 3.88 | 0.630 | 4 | 0.375 |
| (S)RR0200 | 2 | 6.00 | 3.63 | 4.75 | 0.750 | 4 | 0.375 |
| (S)RR0250 | 2.5 | 7.00 | 4.13 | 5.50 | 0.750 | 4 | 0.375 |
| (S)RR0300 | 3 | 7.50 | 4.63 | 6.00 | 0.750 | 4 | 0.375 |
| (S)RR0400 | 4 | 9.00 | 5.88 | 7.50 | 0.750 | 8 | 0.375 |
| (S)RR0500 | 5 | 10.00 | 6.88 | 8.50 | 0.880 | 8 | 0.375 |
| (S)RR0600 | 6 | 11.00 | 7.88 | 9.50 | 0.880 | 8 | 0.375 |
| (S)RR0800 | 8 | 13.50 | 9.88 | 11.75 | 0.880 | 8 | 0.375 |
| (S)RR1000 | 10 | 16.00 | 12.13 | 14.25 | 1.000 | 12 | 0.375 |
| (S)RR1200 | 12 | 19.00 | 14.50 | 17.00 | 1.000 | 12 | 0.375 |
| (S)RR1400 | 14 | 21.00 | 16.50 | 18.75 | 1.130 | 12 | 0.375 |
| (S)RR1600 | 16 | 23.50 | 18.50 | 21.25 | 1.130 | 16 | 0.375 |
| (S)RR1800 | 18 | 25.00 | 20.50 | 22.75 | 1.250 | 16 | 0.375 |
| (S)RR2000 | 20 | 27.50 | 22.63 | 25.00 | 1.250 | 20 | 0.375 |
| (S)RR2200 | 22 | 29.50 | 24.63 | 27.25 | 1.380 | 20 | 0.375 |
| (S)RR2400 | 24 | 32.00 | 26.63 | 29.50 | 1.380 | 20 | 0.375 |
| (S)RR2600 | 26 | 34.25 | 28.88 | 31.75 | 1.380 | 24 | 0.375 |
| (S)RR2800 | 28 | 36.50 | 30.88 | 34.00 | 1.380 | 28 | 0.375 |
| (S)RR3000 | 30 | 38.75 | 32.88 | 36.00 | 1.380 | 28 | 0.375 |
| (S)RR3200 | 32 | 41.75 | 34.88 | 38.50 | 1.630 | 28 | 0.375 |
| (S)RR3400 | 34 | 43.75 | 37.00 | 40.50 | 1.630 | 32 | 0.375 |
| (S)RR3600 | 36 | 46.00 | 39.00 | 42.75 | 1.630 | 32 | 0.375 |
| (S)RR4000 | 40 | 50.75 | 43.00 | 47.25 | 1.630 | 36 | 0.375 |
| (S)RR4200 | 42 | 53.00 | 45.25 | 49.50 | 1.630 | 36 | 0.375 |
| (S)RR4400 | 44 | 55.25 | 47.25 | 51.75 | 1.630 | 40 | 0.375 |
| (S)RR4800 | 48 | 59.50 | 51.25 | 56.00 | 1.630 | 44 | 0.375 |
| (S)RR5000 | 50 | 61.75 | 53.25 | 58.25 | 1.880 | 44 | 0.375 |
| (S)RR5200 | 52 | 64.00 | 55.25 | 60.50 | 1.880 | 44 | 0.375 |
| (S)RR5400 | 54 | 66.25 | 57.25 | 62.75 | 2.000 | 44 | 0.375 |

1 Set = 4 Split Ring Halves (thru 28") and 8 Split Ring Quarters (for 30" or greater)

Notes:

- a. Available in are Silver Zinc Plated Steel, Standard Grade 304 and Dual Grade 316/316L Stainless Steel.
- b. Navy or DIN drilling available on special order basis.

ALL DIMENSIONS ARE IN INCHES UNLESS OTHERWISE STATED.

PART NUMBER STRUCTURE

| Part Number Section | Options |
|---------------------|--|
| Type | RR = Zink Plated Steel SRR = Stainless Steel |
| Size | XXXX = Size in inches going out 2 decimal places |
| Material | 304 = Standard Grade 304 Stainless Steel 316L = Dual Grade 316/316L Stainless Steel |
| Other | S = Set |

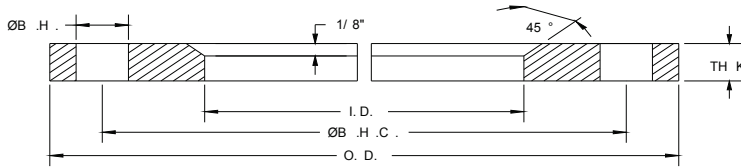

Split Retaining Rings - Class 300 Drill Pattern (Zinc Plated Steel)

| API Part Number | Size | O.D. | I.D. | Ø B.H.C. | Ø B.H. | # B.H | THK |
|-----------------|------|-------|-------|----------|--------|-------|-------|
| RR0100-30 | 1 | 4.88 | 2.38 | 3.50 | 0.750 | 4 | 0.375 |
| RR0125-30 | 1.25 | 5.20 | 2.63 | 3.88 | 0.750 | 4 | 0.375 |
| RR0150-30 | 1.5 | 6.13 | 2.88 | 4.50 | 0.880 | 4 | 0.375 |
| RR0200-30 | 2 | 6.50 | 3.63 | 5.00 | 0.880 | 8 | 0.375 |
| RR0250-30 | 2.5 | 7.50 | 4.13 | 5.88 | 0.880 | 8 | 0.375 |
| RR0300-30 | 3 | 8.25 | 4.63 | 6.63 | 0.880 | 8 | 0.375 |
| RR0400-30 | 4 | 10.00 | 5.88 | 7.88 | 0.880 | 8 | 0.375 |
| RR0500-30 | 5 | 11.00 | 6.88 | 9.25 | 0.880 | 8 | 0.375 |
| RR0600-30 | 6 | 12.50 | 7.88 | 10.63 | 0.880 | 12 | 0.375 |
| RR0800-30 | 8 | 15.00 | 9.88 | 13.00 | 1.000 | 12 | 0.375 |
| RR1000-30 | 10 | 17.50 | 12.13 | 15.25 | 1.130 | 16 | 0.375 |
| RR1200-30 | 12 | 20.50 | 14.50 | 17.75 | 1.250 | 16 | 0.375 |
| RR1400-30 | 14 | 23.00 | 16.50 | 20.25 | 1.250 | 20 | 0.375 |
| RR1600-30 | 16 | 25.50 | 18.50 | 22.50 | 1.250 | 20 | 0.375 |
| RR1800-30 | 18 | 28.00 | 20.50 | 24.75 | 1.250 | 24 | 0.375 |
| RR2000-30 | 20 | 30.50 | 22.63 | 27.00 | 1.250 | 24 | 0.375 |
| RR2400-30 | 24 | 36.00 | 26.63 | 32.00 | 1.500 | 24 | 0.375 |

1 Set = 4 Split Ring Halves.

Notes:

- a. Rings are Steel & Silver Zinc Plated.
- b. Navy or DIN drilling available on special order basis.

ALL DIMENSIONS ARE IN INCHES UNLESS OTHERWISE STATED.