

# Rubber Expansion Joints & Accessories



# Rubber Expansion Joints - *Flange x Flange* For Series: AMS, AMT, SAMS, & SAMT

## PART NUMBER STRUCTURE

Part Number Section	Options
Type	AMS = Single Sphere (Steel) SAMS = Single Sphere (Stainless Steel) AMT = Twin Sphere (Steel) SAMT = Twin Sphere (Stainless Steel)
Size	XXXX = Size in inches going out 2 decimal places
Body Material	NE = Neoprene EP = EPDM BN = Buna-N/Nitrile/NBR
Flange Material	STL = Zinc Plated Steel 304L = 304L Stainless Steel 316L = 316L Stainless Steel
Class	150 = 150# Drilling 300 = 300# Drilling PXX = DIN PN10/PN16Drilling (available upon request)
Example	AMS0200-NE-STL-150 = Single Sphere Expansion Joint with Neoprene Body and Steel Flanges with 150# Drill Pattern

## OPERATING CONDITIONS

Size Range	1" - 12"	14" - 24"
Operating Pressure	up to 214 psi	up to 114 psi
Operating Temp Range*	14°F- 170°F (Neoprene) 14°F- 210°F (EPDM) 14°F- 170°F (Buna-N/Nitrile/NBR)	14°F- 170°F (Neoprene) 14°F- 210°F (EPDM) 14°F- 170°F (Buna-N/Nitrile/NBR)
Burst Pressure	853 psi	340 psi
Vacuum Rating*	Contact API Sales	Contact API Sales

## MATERIALS

Part	Part Description	Material
1	Flanges	Mild Steel - Zinc Plated steel or Stainless Steel
2	Reinforcing Wire	Mild Steel
3	Tube	Synthetic Rubber
4	Cover	Synthetic Rubber
5	Reinforcing Cord	Synthetic Fiber

**\*\* - Warnings:**

- a. Pressure ratings listed in the above table are for up to 110 °F (for Neoprene), and 125 °F (for EPDM). For elevated temperature service, please contact API Sales for actual working pressure ratings.
- b. Limit rods are required in systems that are unanchored and recommended in all other applications.
- c. Not for use in steam applications

# Single Sphere Rubber Expansion Joints - *Flange x Flange* (AMS & SAMS Series)

## FEATURES

- Applicable for suction and delivery (discharge).
- Provides sound and vibration isolation.
- Gaskets and packing are not required.
- Floating flanges allow for easy installation.
- Prevents piping system and equipment breakdown by absorbing elongation and contraction caused by temperature variances.
- Absorbs water pulsation and minimizes water hammering.
- DIN drilled flanges available upon request (See DIN Flange section for dimensions)

## APPLICATIONS

- Pumps & air compressors in air conditioning system & sanitary equipment.
- Refrigeration systems and blowers in industrial plant equipment.
- Feed-water and drainage equipment in marine piping systems.
- Applicable for use in power generation and chemical plants.

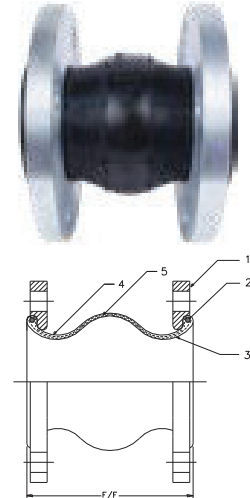

## DIMENSION & ALLOWABLE MOVEMENTS

ALL DIMENSIONS ARE IN INCHES UNLESS OTHERWISE STATED.

API Part Number	Size in	Face to Face Dimensions in	Allowable Motion Ratings*				Installation Tolerances			
			Compression	Elongation	Lateral	Angular	Compression	Elongation	Lateral	Angular
(S)AMS0100	1	6	0.50	0.38	0.50	15°	0.19	0.13	0.25	5°
(S)AMS0125	1.25	6	0.50	0.38	0.50	15°	0.19	0.13	0.25	5°
(S)AMS0150	1.5	6	0.50	0.38	0.50	15°	0.19	0.13	0.25	5°
(S)AMS0200	2	6	0.50	0.38	0.50	15°	0.19	0.13	0.25	5°
(S)AMS0250	2.5	6	0.50	0.38	0.50	15°	0.19	0.13	0.25	5°
(S)AMS0300	3	6	0.50	0.38	0.50	15°	0.19	0.13	0.25	5°
(S)AMS0400	4	6	0.63	0.38	0.50	15°	0.19	0.13	0.25	5°
(S)AMS0500	5	6	0.63	0.38	0.50	15°	0.19	0.13	0.25	5°
(S)AMS0600	6	6	0.63	0.38	0.50	15°	0.19	0.13	0.25	5°
(S)AMS0800	8	6	0.63	0.38	0.50	15°	0.19	0.13	0.25	5°
(S)AMS1000	10	8	0.63	0.50	0.75	15°	0.19	0.13	0.25	5°
(S)AMS1200	12	8	0.75	0.50	0.75	15°	0.19	0.13	0.25	5°
(S)AMS1400	14	8	0.75	0.50	0.75	15°	0.19	0.13	0.25	5°
(S)AMS1600	16	8	0.75	0.50	0.75	15°	0.19	0.13	0.25	5°
(S)AMS1800	18	8	0.75	0.50	0.75	15°	0.19	0.13	0.25	5°
(S)AMS2000	20	8	0.75	0.50	0.75	15°	0.19	0.13	0.25	5°
(S)AMS2400	24	10	0.75	0.50	0.75	15°	0.19	0.13	0.25	5°

**Warning:** Do not elongate rubber expansion joints when installing for suction service.

“\*” - Non Concurrent Ratings.

Notes:

- a. For all expansion joint configurations - See section 10.2

# Twin Sphere Rubber Expansion Joints - *Flange x Flange* (AMT & SAMT Series)

## FEATURES

- Applicable for suction and delivery (discharge).
- Designed for greater compression, elongation, and angular movement than the single sphere expansion joint.
- Excellent for absorbing thermal expansion and eliminating sound and vibration.
- Gaskets and packing not required.
- Good electrical insulator.
- Absorbs water pulsation and minimizes water hammering.
- DIN drilled flanges available upon request (See DIN Flange section for dimensions)



## APPLICATIONS

- Pressure piping systems in building equipment and general industrial plants.
- Pump and turbine lines used for power generation plants, industrial machinery and universal pump blowers.
- Feed-water & drainage lines for waterworks & sanitary piping systems.
- Pipelines for industrial plants and shipbuilding yards.

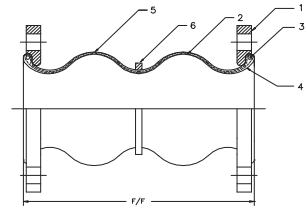

## DIMENSION & ALLOWABLE MOVEMENTS

ALL DIMENSIONS ARE IN INCHES UNLESS OTHERWISE STATED.

API Part Number	Size	Face to Face Dimension	Allowable Motion Ratings*				Installation Tolerances			
			Compression	Elongation	Lateral	Angular	Compression	Elongation	Lateral	Angular
(S)AMT0100	1	7.00	1.50	0.75	1.25	35°	0.25	0.13	0.31	10°
(S)AMT0125	1.25	7.00	1.50	0.75	1.25	35°	0.25	0.13	0.31	10°
(S)AMT0150	1.5	7.00	2.00	1.13	1.75	35°	0.25	0.13	0.31	10°
(S)AMT0200	2	7.00	2.00	1.13	1.75	35°	0.25	0.13	0.31	10°
(S)AMT0250	2.5	7.00	2.00	1.13	1.75	35°	0.25	0.13	0.31	10°
(S)AMT0300	3	7.00	2.00	1.38	1.75	35°	0.25	0.13	0.31	10°
(S)AMT0400	4	9.00	2.00	1.38	1.56	35°	0.25	0.13	0.31	10°
(S)AMT0500	5	9.00	2.00	1.38	1.56	30°	0.25	0.13	0.38	10°
(S)AMT0600	6	9.00	2.00	1.38	1.56	30°	0.25	0.13	0.38	10°
(S)AMT0800	8	13.00	2.38	1.38	1.38	30°	0.25	0.13	0.50	10°
(S)AMT1000	10	13.00	2.38	1.38	1.38	30°	0.25	0.13	0.50	10°
(S)AMT1200	12	13.00	2.38	1.38	1.38	20°	0.25	0.13	0.50	10°
(S)AMT1400	14	13.75	1.56	1.13	1.13	20°	0.25	0.13	0.31	10°
(S)AMT1600	16	13.75	1.56	1.13	1.13	20°	0.25	0.13	0.31	10°
(S)AMT1800	18	13.75	1.56	1.13	1.13	20°	0.25	0.13	0.31	10°
(S)AMT2000	20	13.75	1.56	1.13	1.13	20°	0.25	0.13	0.31	10°
(S)AMT2400	24	13.75	1.56	1.13	1.13	20°	0.25	0.13	0.31	10°

**Warning:** Do not elongate rubber expansion joints when installing for suction service.

“\*” – Non Concurrent Ratings.

Notes:

- a. For all expansion joint configurations - See section 10.2

# Twin Sphere Rubber Expansion Joints - *Union x Union*

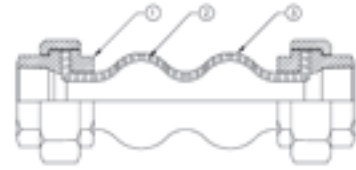

## FEATURES

- Efficient noise and vibration isolation.
- Ability to absorb large displacement due to eccentric, axial, and angular movement.
- Applicable for both suction and discharge.
- Female Threaded Unions allow for easy installation.

## APPLICATIONS

- Vibration isolation for small pumps and circular pumps.
- Sewage disposal purifier line.
- Vibration isolation for air-conditioners and pipes.

## DIMENSION & ALLOWABLE MOVEMENTS

ALL DIMENSIONS ARE IN INCHES UNLESS OTHERWISE STATED.

API Part Number	Size	Face to Face dimension (L)	Allowable Motion Ratings				Approximate Weight (lbs)
			Compression	Elongation	Lateral	Angular	
AMU0050-XX	0.5	8.00	0.88	0.25	0.88	45°	1.5
AMU0075-XX	0.75	8.00	0.88	0.25	0.88	45°	1.8
AMU0100-XX	1	8.00	0.88	0.25	0.88	45°	2.8
AMU0125-XX	1.25	8.00	0.88	0.25	0.88	45°	3.5
AMU0150-XX	1.5	8.00	0.88	0.25	0.88	45°	4.0
AMU0200-XX	2	8.00	0.88	0.25	0.88	45°	5.0

**Warning:** Do not elongate rubber expansion joints when installing for suction service.

\*\*\* - Non Concurrent Ratings.

## PART NUMBER STRUCTURE

Part Number Section	Options
Type	AMU = Twin Sphere Union Expansion Joint
Size	XXXX = Size in inches going out 2 decimal places
Body Material *Denoted with "XX"	EP = EPDM NE = Neoprene

## OPERATING CONDITIONS

Operating Pressure	up to 150 psi
Normal Operating Temp.	14° - 158° F
Vacuum Rating	25" Hg
Burst Pressure	750 psi

## MATERIALS

Part	Part Description	Material
1	Threaded Union	Malleable Iron
2	Reinforcing Cloth	Nylon Fabric
3	Elastomer	EPDM

\*\*\* - Warning:

Pressure ratings listed in the above table are for up to 110 °F (for Neoprene), and 125 °F (for EPDM). For elevated temperature service, please contact API Sales for actual working pressure ratings.

## Control Units - Mild Steel (Zinc Plated)\*\*

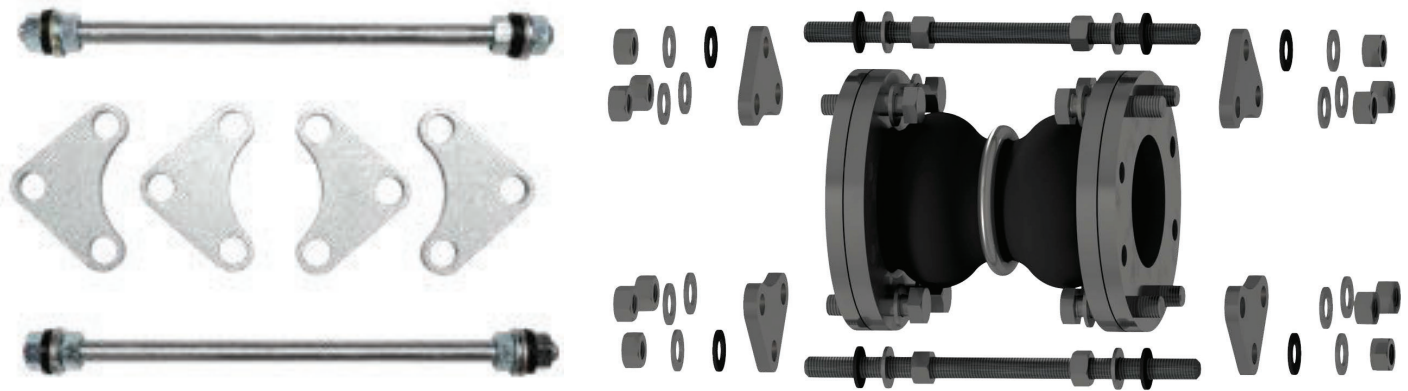

ALL DIMENSIONS ARE IN INCHES UNLESS OTHERWISE STATED.

Complete unit* API Part Number	Size	Expansion Joint Application	Gusset Plate Part Number	Plate THK.	Plate Weight (lbs)	Control ROD Part Number***	Approximate Weight (lbs)
CRU0150	1.5	SINGLE/TWIN	CRP0150	0.50	0.8	CR0625-14S	6.4
CRU0200	2	SINGLE/TWIN	CRP0200	0.50	1.0	CR0625-14S	7.2
CRU0250	2.5	SINGLE/TWIN	CRP0250	0.50	1.3	CR0625-14S	8.4
CRU0300	3	SINGLE/TWIN	CRP0300	0.50	1.6	CR0625-14S	9.6
CRUS0400	4	SINGLE	CRP0400	0.50	1.4	CR0625-14S	8.8
CRUT0400	4	TWIN	CRP0400	0.50	1.4	CR0625-17T	9.2
CRUS0500	5	SINGLE	CRP0500	0.50	1.5	CR0625-14S	9.2
CRUT0500	5	TWIN	CRP0500	0.50	1.5	CR0625-17T	9.6
CRUS0600	6	SINGLE	CRP0600	0.50	1.7	CR0625-14S	10.0
CRUT0600	6	TWIN	CRP0600	0.50	1.7	CR0625-17T	10.4
CRUS0800	8	SINGLE	CRP0800	0.50	2.1	CR0875-18S	16.4
CRUT0800	8	TWIN	CRP0800	0.50	2.1	CR0875-23T	17.6
CRUS1000	10	SINGLE	CRP1000	0.75	3.5	CR0875-18S	22.0
CRUT1000	10	TWIN	CRP1000	0.75	3.5	CR0875-23T	23.2
CRUS1200	12	SINGLE	CRP1200	0.75	5.0	CR1125-18S	34.0
CRUT1200	12	TWIN	CRP1200	0.75	5.0	CR1125-23T	36.0
CRUS1400	14	SINGLE	CRP1416	0.75	5.0	CR1125-18S	34.0
CRUT1400	14	TWIN	CRP1416	0.75	5.0	CR1125-23T	36.0
CRUS1600	16	SINGLE	CRP1416	0.75	5.0	CR1125-18S	34.0
CRUT1600	16	TWIN	CRP1416	0.75	5.0	CR1125-23T	36.0
CRUS1800	18	SINGLE	CRP1820	0.75	6.0	CR1125-18S	38.0
CRUT1800	18	TWIN	CRP1820	0.75	6.0	CR1125-23T	40.0
CRUS2000	20	SINGLE	CRP1820	0.75	6.0	CR1125-18S	38.0
CRUT2000	20	TWIN	CRP1820	0.75	6.0	CR1125-23T	40.0
CRUS2400	24	SINGLE	CRP2400	1.00	7.5	CR1250-18S	47.0
CRUT2400	24	TWIN	CRP2400	1.00	7.5	CR1250-23T	49.0

**Warning:** Do not elongate rubber expansion joints when installing for suction service.

\*\* - Complete units consist of the following: 2 Rods; 4 Plates; 8 Nuts; 8 Steel Washers; & 8 Neoprene Washers.

If needed, 3 or more rod sets are available upon request.

\*\*\* - Sets are also available in 304/316 Stainless Steel.

\*\*\*\* - Single (S); Twin (T).

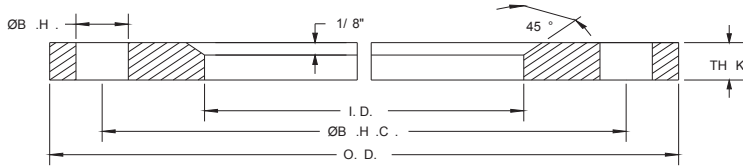

## Split Retaining Rings - Class 150 Drill Pattern

API Part Number	Size	O.D.	I.D.	Ø B.H.C.	Ø B.H.	# B.H	THK
(S)RR0050	0.5	3.50	1.50	2.38	0.630	4	0.375
(S)RR0075	0.75	3.88	1.88	2.75	0.630	4	0.375
(S)RR0100	1	4.25	2.38	3.13	0.630	4	0.375
(S)RR0125	1.25	4.63	2.63	3.50	0.630	4	0.375
(S)RR0150	1.5	5.00	2.88	3.88	0.630	4	0.375
(S)RR0200	2	6.00	3.63	4.75	0.750	4	0.375
(S)RR0250	2.5	7.00	4.13	5.50	0.750	4	0.375
(S)RR0300	3	7.50	4.63	6.00	0.750	4	0.375
(S)RR0400	4	9.00	5.88	7.50	0.750	8	0.375
(S)RR0500	5	10.00	6.88	8.50	0.880	8	0.375
(S)RR0600	6	11.00	7.88	9.50	0.880	8	0.375
(S)RR0800	8	13.50	9.88	11.75	0.880	8	0.375
(S)RR1000	10	16.00	12.13	14.25	1.000	12	0.375
(S)RR1200	12	19.00	14.50	17.00	1.000	12	0.375
(S)RR1400	14	21.00	16.50	18.75	1.130	12	0.375
(S)RR1600	16	23.50	18.50	21.25	1.130	16	0.375
(S)RR1800	18	25.00	20.50	22.75	1.250	16	0.375
(S)RR2000	20	27.50	22.63	25.00	1.250	20	0.375
(S)RR2200	22	29.50	24.63	27.25	1.380	20	0.375
(S)RR2400	24	32.00	26.63	29.50	1.380	20	0.375
(S)RR2600	26	34.25	28.88	31.75	1.380	24	0.375
(S)RR2800	28	36.50	30.88	34.00	1.380	28	0.375
(S)RR3000	30	38.75	32.88	36.00	1.380	28	0.375
(S)RR3200	32	41.75	34.88	38.50	1.630	28	0.375
(S)RR3400	34	43.75	37.00	40.50	1.630	32	0.375
(S)RR3600	36	46.00	39.00	42.75	1.630	32	0.375
(S)RR4000	40	50.75	43.00	47.25	1.630	36	0.375
(S)RR4200	42	53.00	45.25	49.50	1.630	36	0.375
(S)RR4400	44	55.25	47.25	51.75	1.630	40	0.375
(S)RR4800	48	59.50	51.25	56.00	1.630	44	0.375
(S)RR5000	50	61.75	53.25	58.25	1.880	44	0.375
(S)RR5200	52	64.00	55.25	60.50	1.880	44	0.375
(S)RR5400	54	66.25	57.25	62.75	2.000	44	0.375

1 Set = 4 Split Ring Halves (thru 28") and 8 Split Ring Quarters (for 30" or greater)

**Notes:**

- a. Available in are Silver Zinc Plated Steel, Standard Grade 304 and Dual Grade 316/316L Stainless Steel.
- b. Navy or DIN drilling available on special order basis.

**ALL DIMENSIONS ARE IN INCHES UNLESS OTHERWISE STATED.**

### PART NUMBER STRUCTURE

Part Number Section	Options
Type	RR = Zinc Plated Steel SRR = Stainless Steel
Size	XXXX = Size in inches going out 2 decimal places
Material	4L = Standard Grade 304 Stainless Steel 16L = Dual Grade 316/316L Stainless Steel
Other	S = Set
Example	SRR2000-16L-S

DC# 0524

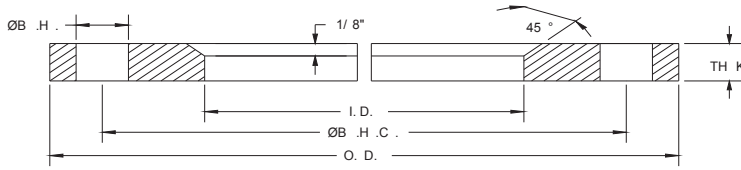

## Split Retaining Rings - Class 300 Drill Pattern (Zinc Plated Steel)

API Part Number	Size	O.D.	I.D.	Ø B.H.C.	Ø B.H.	# B.H	THK
RR0100-30	1	4.88	2.38	3.50	0.750	4	0.375
RR0125-30	1.25	5.20	2.63	3.88	0.750	4	0.375
RR0150-30	1.5	6.13	2.88	4.50	0.880	4	0.375
RR0200-30	2	6.50	3.63	5.00	0.880	8	0.375
RR0250-30	2.5	7.50	4.13	5.88	0.880	8	0.375
RR0300-30	3	8.25	4.63	6.63	0.880	8	0.375
RR0400-30	4	10.00	5.88	7.88	0.880	8	0.375
RR0500-30	5	11.00	6.88	9.25	0.880	8	0.375
RR0600-30	6	12.50	7.88	10.63	0.880	12	0.375
RR0800-30	8	15.00	9.88	13.00	1.000	12	0.375
RR1000-30	10	17.50	12.13	15.25	1.130	16	0.375
RR1200-30	12	20.50	14.50	17.75	1.250	16	0.375
RR1400-30	14	23.00	16.50	20.25	1.250	20	0.375
RR1600-30	16	25.50	18.50	22.50	1.250	20	0.375
RR1800-30	18	28.00	20.50	24.75	1.250	24	0.375
RR2000-30	20	30.50	22.63	27.00	1.250	24	0.375
RR2400-30	24	36.00	26.63	32.00	1.500	24	0.375

1 Set = 4 Split Ring Halves.

Notes:

- a. Rings are Steel & Silver Zinc Plated.
- b. Navy or DIN drilling available on special order basis.

**ALL DIMENSIONS ARE IN INCHES UNLESS OTHERWISE STATED.**