

Rubber Expansion Joints Installation Guide

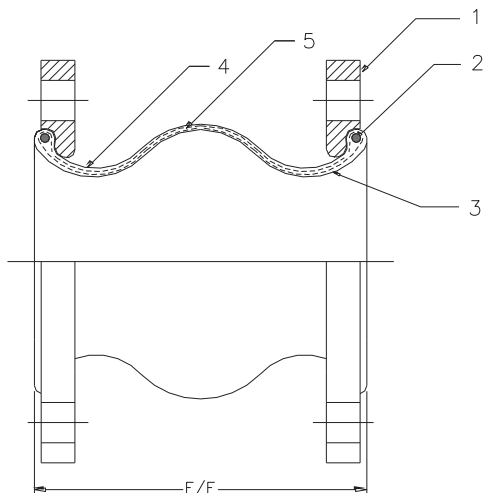

Installation Instructions - Series AMS/AMT Expansion Joints

PREPARATION

- 1. Check Application Criteria.** Double-check the performance limits of the expansion joint against the anticipated operating conditions. Expansion joints should never be subjected to operating conditions beyond the temperature, pressure, and/or vacuum service recommendations of API International. If the total motions due to initial installation and the movements of pipelines during system operation exceed the published maximum allowable movement, then the pipeline should be altered to reduce the initial installation movements. Also, the line should be anchored to EJMA (Expansion Joint Manufacturers Association) specifications to limit the pipe movements that the expansion joint must absorb. For elevated temperatures (above 110° F), contact API Sales for maximum operating pressures.
- 2. Check Location.** Generally, the proper location of rubber expansion joints is installed close to a main anchor point. Following the joint in the line, a pipe guide, or series of guides, should be installed to keep the pipe aligned and prevent undue displacement (of the pipe). This is the simplest application of a joint, namely, to absorb the expansion and contraction of a pipeline between fixed anchor points.
- 3. Check Expansion Joint.** Check the interior, exterior, and flange faces for damage or cracks prior to placing into service. The cover is designed to keep harmful material from penetrating the carcass of the joint.
- 4. Check Alignment.** Piping should be lined up within a maximum of +/- (1/8"). If piping offset is greater than 1/8", and can not be corrected, a special offset joint should be designed and used for the application.
- 5. Check Support.** Piping must be supported by hangers or anchors, so that its weight is not carried by the expansion joint.
- 6. Check Flanges.** Be sure that companion flanges to be mated with the flanges of the expansion joint are clean. Used parts should be carefully examined for reasonable smoothness, and any adhering particles of old gasketing or other foreign material should be scraped off, taking care not to gouge or mutilate the flange surface. When attaching beaded end flange expansion joints to raised face flanges, the use of ring gaskets are required to prevent metal flange faces from cutting the rubber bead during installation.

Note: Never install expansion joints next to wafer type check or butterfly valves. Serious damage to the rubber flange bead can result due to the lack of flange mating surface and/or bolt connection.

WARNING: Expansion joints may operate in pipelines or equipment carrying fluids and/or gases at elevated temperatures and pressures and may transport hazardous materials. Precaution should be taken to periodically inspect the joints and protect personnel in the event of leakage or splash. Rubber expansion joints should not be installed in areas where inspection is not possible.

Note: Some of this information has been replicated from the "Fluid Sealing Association Handbook" on Non-Metallic Expansion Joints.

Installation Instructions - Series AMS/AMT

Expansion Joints

INSTALLATION

Apply Lubricant. Rubber expansion joints face flanges may be painted with a solution of graphite in water or glycerin to prevent adherence of joint to pipe flanges. Petroleum lubricants should not be used.

Insert Expansion Joints into Position. Do not use gaskets for AMS/AMT series. Care must be taken when pushing the joint into the breach between the mating flanges so as not to roll the leading edge of the joint out of its flange groove. Do not bolt directly to another component with an elastomeric face or to a specialty flange without inserting a solid full face metallic gasket.

Insert Bolts. Bolts should be inserted from the arch side (so that bolt heads are adjacent to arch) to ensure that bolts do not interfere with arch during periods of compression.

Tighten Bolts. Tighten all bolts gradually and equally by alternating around the flange in a diagonal manner to the recommended torque values listed below. If a water tight seal is not achieved after initial tightening, slightly tighten nuts until leak is sealed. Do not over tighten to the point where there is metal to metal contact between the rotating flange and the pipe flange. Check bolt tightness at least one week after system is started up and periodically thereafter. As any rubber-like material takes a “set” after a period of compression, the bolts may loosen and result in a broken seal. In a hot and cold water system, the bolts should be checked before changing from one medium to another.

RECOMMENDED BOLTING TORQUE (AMS/AMT Series):

Sizes: 1” thru 2” - 45 ft-lb. 2-1/2” thru 8” - 60 ft-lb. 10” thru 20” - 80 ft-lb.

Control Rods. For piping systems that are not anchored, control rods must be used. Control rods are always recommended as a safety precaution (even when system is properly anchored and guided).

Additional Tips.

- Insulation over a non-metallic rubber expansion joint is not recommended; however, if the insulation is required, it should be made removable to permit easy access to the flange area, to check bolting.
- Do not weld in the vicinity of a non-metallic expansion joint.
- If the expansion joint is to be installed outdoors, appropriate outer cover material must be used to withstand the ozone, sunlight...etc.

WARNING: Expansion joints may operate in pipelines or equipment carrying fluids and/or gases at elevated temperatures and pressures and may transport hazardous materials. Precaution should be taken to periodically inspect the joints and protect personnel in the event of leakage or splash. Rubber expansion joints should not be installed in areas where inspection is not possible.

Note: Some of this information has been replicated from the “Fluid Sealing Association Handbook” on Non-Metallic Expansion Joints.