

VISIT APIINT.COM FOR MORE INFORMATION.

YOUR SOURCE FOR PIPE FITTINGS & CUSTOM SOLUTIONS

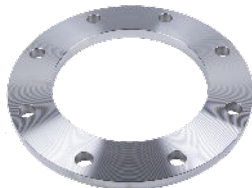

FLANGES

Meet wide variety of standards (ANSI, ASTM, AWWA, BS, DIN and JIS)

Broad range of types, sizes, materials (100% Domestic, Buy America & Imported) and accessories, like gaskets and flange adapters



FITTINGS & ACCESSORIES

Large inventory of grooved fittings (KLAMPz), threaded couplings, pipe nipples, elbows, pump motor brackets, rain caps and weld cones

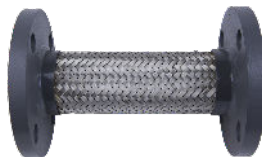

PUMP CONNECTORS

Flanged and threaded pump connectors



VALVES

Variety of gear and lever operated butterfly valves, check valves and pressure relief valves, including accessories like valve extensions



EXPANSION JOINTS

Multiple sizes of flanged and union expansion joints, along with accessories like control units and split retaining rings



CUSTOM PARTS

Diverse selection of custom parts and assemblies manufactured and stocked for OEM Manufacturers in the Agriculture, Exhaust, HVAC & Water Works markets

MACHINING & MANUFACTURING

- Experience with a wide variety of products, sizes, materials and specifications utilizing Buy America, AIS or Import materials.
- Short lead times that allow you to get products to customers when they need them.
- Support fast turn modifications to stock items.
- Quality control technicians verify that all products meet customer requirements.

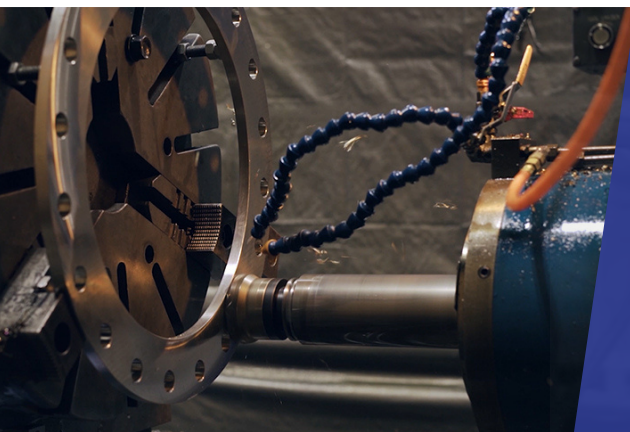

EXPANSION JOINTS

Suitable for suction and delivery applications, Single-Sphere Molded Rubber Expansion Joints reduce noise and vibrations. These molded rubber expansion joints can absorb motion and reduce stress. They come with ANSI Class #150 drilled flanges and can be customized with ANSI Class #300 and DIN-rated flanges.

FEATURES

- Applicable for suction and delivery (discharge).
- Provides sound and vibration isolation.
- Gaskets and packing are not required. Floating flanges allow for easy installation.
- Prevents piping system and equipment breakdown by absorbing elongation and contraction caused by temperature variances.
- Absorbs water pulsation and minimizes water hammering.
- DIN drilled flanges available upon request (See DIN Flange section for dimensions).
- Working pressure ratings based on 4:1 safety margin (at 70°F).

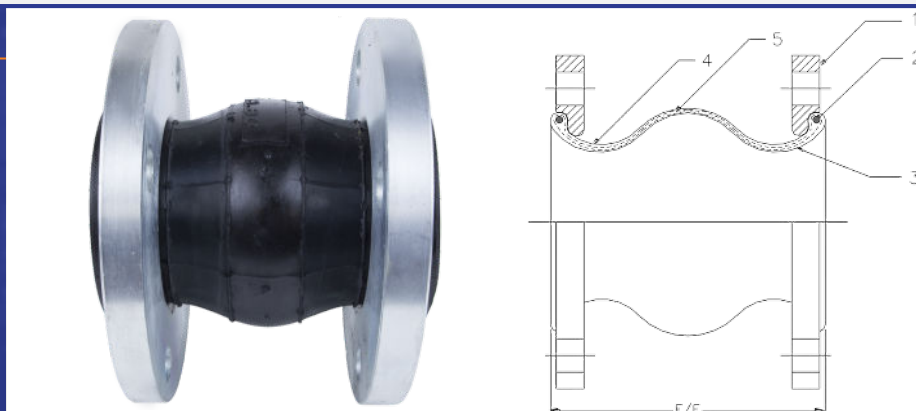

API Part Number	Size	Face to Face Dimensions	Allowable Motion Ratings*				Installation Tolerances			
			Compression	Elongation	Lateral	Angular	Compression	Elongation	Lateral	Angular
(S)AJS0100	1	6	0.50	0.38	0.50	20°	0.19	0.13	0.25	5°
(S)AJS0125	1.25	6	0.50	0.38	0.50	20°	0.19	0.13	0.25	5°
(S)AJS0150	1.5	6	0.50	0.38	0.50	20°	0.19	0.13	0.25	5°
(S)AJS0200	2	6	0.50	0.38	0.50	20°	0.19	0.13	0.25	5°
(S)AJS0250	2.5	6	0.50	0.38	0.50	15°	0.19	0.13	0.25	5°
(S)AJS0300	3	6	0.50	0.38	0.50	15°	0.19	0.13	0.25	5°
(S)AJS0400	4	6	0.63	0.38	0.50	15°	0.19	0.13	0.25	5°
(S)AJS0500	5	6	0.63	0.38	0.50	15°	0.19	0.13	0.25	5°
(S)AJS0600	6	6	0.63	0.38	0.50	15°	0.19	0.13	0.25	5°
(S)AJS0800	8	6	0.63	0.38	0.50	15°	0.19	0.13	0.25	5°
(S)AJS1000	10	8	0.75	0.50	0.75	15°	0.19	0.13	0.25	5°
(S)AJS1200	12	8	0.75	0.50	0.75	15°	0.19	0.13	0.25	5°
(S)AJS1400	14	8	1.00	0.63	0.75	15°	0.19	0.13	0.25	5°
(S)AJS1600	16	8	1.00	0.63	0.75	15°	0.19	0.13	0.25	5°
(S)AJS1800	18	8	1.00	0.63	0.75	15°	0.19	0.13	0.25	5°
(S)AJS2000	20	8	1.00	0.63	0.75	15°	0.19	0.13	0.25	5°
(S)AJS2400	24	10	1.00	0.63	0.75	15°	0.19	0.13	0.25	5°

Warning: Do not elongate rubber expansion joints when installing for suction service. “*” - Non Concurrent Ratings.

APPLICATIONS

- Pumps & air compressors in air conditioning system & sanitary equipment.
- Refrigeration systems and blowers in industrial plant equipment.
- Feed-water and drainage equipment in marine piping systems.
- Applicable for use in Power Generation, Chemical Plants, & Marine applications

OPERATING CONDITIONS

Size Range	1" - 12"	14" - 24"
Operating Pressure	225 psi (up to 160°F)	150 psi (up to 160°F)
Burst Pressure	900 psi (at 70°F)	600 psi (at 70°F)
Vacuum Rating*	26 in/hg	15 in/hg
Operating Temp Range*	14°F - 180°F (Neoprene) 14°F - 210°F (EPDM) 14°F - 180°F (Buna-N/Nitrile/NBR)	

PART NUMBER STRUCTURE

Part Number Selection	Options
Type	AJS = Single Sphere (Steel) SAJS = Single Sphere (Stainless Steel)
Size	XXXX = Size in inches going out 2 decimal places
Body Material	NE = Neoprene EP = EPDM BN = Buna-N/Nitrile/NBR
Flange Material	STL=Zinc Plated Steel 304L=304L Stainless Steel 316L=316L Stainless Steel
Class	150=150# Drilling / 300=300# Drilling / PXX=DIN PN16 Drilling
Example	AJS0200-NE-STL-150 = Single Sphere Expansion Joint with Neoprene Body and Steel Flanges with 150# Drill Pattern

MATERIALS

Part	Part Description	Material
1	Flanges	Mild Steel - Plated or Stainless Steel
2	Reinforcing Wire	Mild Steel
3	Tube	Synthetic Rubber
4	Cover	Synthetic Rubber
5	Reinforcing Cord	Nylon

Notes:

- Pressure ratings listed in the above table are for temperatures up to 160°F. For temperature service above 160°F, please contact API Sales for actual working pressure ratings.
- Limit rods are required in systems that are unanchored and recommended in all other applications.
- Not for use in steam applications